

Limited Warranty:

RE Audio warrants all manufactured electronic products to be free from defects in material and workmanship for a period not to exceed ONE YEAR from the date of purchase.

IMPORTANT WARRANTY NOTICE: RE Audio will only warrant and service products displaying valid RE Audio serial numbers. WARRANTY SERVICE WILL ONLY BE PERFORMED WHEN THE UNIT IS ACCOMPANIED BY A COPY OF THE ORIGINAL SALES RECEIPT FROM AN AUTHORIZED DEALER. All product returned to RE Audio for service MUST be accompanied by a Return Authorization Number, issued by RE Audio in advance of shipment. The Return Authorization Number must be clearly and conspicuously displayed on the shipping carton or RE Audio will refuse delivery.

For Return Authorization Numbers, first call your RE Audio dealer you purchased the products from. The dealer will help you to obtain Return Authorization Numbers. This warranty extends only to the original purchaser and is not transferable. Defective equipment must be returned within the warranty period, freight prepaid, to the RE Audio Factory or an Authorized RE Audio Warranty Station. This warranty covers only defects in materials and workmanship of manufactured electronic products (amplifiers). Incidents of misuse, abuse, neglect, or unauthorized modification will not be covered within the terms of this warranty. RE Audio reserves the right to refuse warranty service under such conditions.

RE Audio WILL NOT BE RESPONSIBLE FOR ANY DAMAGES, WHETHER INCIDENTAL OR CONSEQUENTIAL, RELATED TO THE USE OF THIS OR ANY OTHER PRODUCT BEARING OR SOLD UNDER THE RE Audio BRAND NAME. USE THIS PRODUCT AT YOUR OWN RISK. IMPROPER USE OF THIS PRODUCT CAN RESULT IN PROPERTY DAMAGE, BODILY HARM, AND OR OTHER DAMAGE. RE Audio ASSUMES NO RESPONSIBILITY FOR YOUR HEALTH OR SAFETY.



CTX series



Owners Manual

1000.4 — 4-CH MOSFET
HIGH POWER AMPLIFIER
1600.2 — 2-CH MOSFET
HIGH POWER AMPLIFIER
3200.1] CLASS DE
MONOBLOCK
4200.1] POWER BASS AMPLIFIER



Congratulations

on your selection of a RE Audio *CTX* series amplifier. We take pride in manufacturing our products and you can expect your new amplifier to give you years of trouble-free service. To make your installation as easy and reliable as possible, please read this manual carefully before beginning. If you need more information, your RE Audio Dealer will be glad to help. To locate a RE Audio Dealer near you, go to our web site and look for "Locate Dealer".

CONTENTS

1	••••••••••	Congratulations / TOC
2	••••••••••	Features & Installation
3	••••••~•••••	Wiring Instructions
4	••••••~•••••	Basic Wiring <ul style="list-style-type: none">• Monoblock• 2-channel• 4-channel
7	••••••~•••••	Bridged Wiring <ul style="list-style-type: none">• 2-channel• 4-channel
9	••••••~•••••	Specifications
10	••••••~•••••	Troubleshooting
back	••••••~•••••	Limited Warranty

TROUBLESHOOTING

Before removing your amplifier, refer to the list below and follow the suggested procedures. Always test the speakers and their wires first.

No Output

- Confirm that all terminal strip connections are secure and tight.
- Check both in-line and built-in fuses.
- Confirm that the audio signal source (car radio, equalizer, etc) is connected and is supplying output signal. To check if the amplifier is supplying signal, unplug the RCA cables from the signal source (but leave them plugged into the amp) and briefly tap the center pin of each of the disconnected RCA plugs with your finger. This should produce a noise (feedback) in your speakers.

Only one channel works

- Confirm that all terminal strip connections are secure and tight.
- Check the "BALANCE" control on the head unit (or other source) to verify that it is set to its mid point.
- If you are using the low-level RCA input, reverse the input plugs at the amplifier (switch the R with the L). If the channel which is silent switches to the other side, the problem is either in the head unit/other source or the connecting cables.

Weak output

- Re-adjust the Input Level Control to better suit the input signal.

Noise in the audio

- If the noise is a "whine" whose pitch follows the engine speed, confirm that the amplifier and any other signal sources (head unit, equalizer, etc) are properly grounded.
- If the noise is a "clicking" or "popping" noise whose rate follows the engine speed, this usually means that the vehicle is equipped with resistor spark plugs and wires, or that the ignition is in need of service.
- Check the routing of the speaker and input wires to make sure they are not adjacent to wires which interconnect with lights and other accessories.
- If the above steps fail to improve or clear noise interference, the system should be checked by a authorized RE Audio Dealer.

SPECIFICATIONS

		1000.4	1600.2	3200.1	4200.1
Power Output (RMS)		4 x 80 4 x 160	2 x 200 2 x 400	1 x 600 1 x 1200	1 x 800 1 x 1500
	@ 14.4V	W	—	1 x 1800	1 x 2200
	4Ω	W	—	—	—
	2Ω	100Hz	1 x 800	—	—
	1Ω	1KHz/100Hz	<0.03	< 0.03	< 0.03
	4Ω mono	1KHz/100Hz	90	80	80
Total Harmonic Distortion	4Ω	%	95	—	—
S/N Ratio	Input Short	dB	10~50K	10~300	10~300
Channel Separation @ 4Ω RMS		Hz	40~250	40~250	40~250
Power Band Width (Frequency Response)		Hz	15~40	15~40	15~40
Crossover Frequency	Low Pass	Hz	40~1K	40~1K	—
	Subsonic	dB	0~12	0~18	0~18
	High Pass		—	Yes	Yes
Bass Boost Control @ 45Hz			Yes	Yes	Yes
Wired Remote Control			100	100	100
Gain Control		mV	6	6	6
Input Sensitivity	Low Level	V	22	20	20
Input Impedance	High Level	KΩ	17.32/440	17.32/440	17.32/440
Dimensions [(L) in/mm]		in/mm	18.9/480	18.9/480	18.9/480
Fuse Rating		A	25A x 3	30A x 3	40A x 3
Protection (thermal, overload, short circuit, DC offset)		V	Yes	Yes	Yes
Power Voltage Range			10~16V	10~16V	10~16V

* Specification subject to change without notice

FEATURES

Power Supply

- High-current Matched MOSFET devices
- Magnetic Induction Regulated Drive Power Supply
- — Drive pulse regulation down to 9 volts input(3200.1/4200.1)
- 35 nonosecond Switching Diodes
- All metalized, high temperature, low ESR capacitors
- 504 amps(3200.1) / 1008 ams(4200.1) fo power devices
- High capacity power transformer
- Multiple Bypass capacitors on incoming 12 volt supply
- Time delay turn on
- Pulse-width Modulation power supply(4200.1)
- Thermal, current, and reverse polarity protection
- New stability filter design for reduction in noise

Amplifiers

- Class DE technology utilizing our Elevated Efficiency Plateform(3200.1/4200.1)
- Output stages utilize high-current Matched MOSFET devices
- High speed, audio-grade components in all low level stages
- Platinum plated RCA inputs and connections
- Wide range of sensitivity accepts signal form any head unit including speaker leads
- 24 dB/octave Subsonic Filter(3200.1/4200.1), 24 dB/octave Electronic Crossover
- True line output / Auto bridge feature / Short cirduit protection
- Balanaced Tranceformerless Login Input for the highest possible Damping Factor, Slew Rate and signal-to-Noise ratiro
- 390 amps(3200.1) / 684 amps(4200.1) of output devices
- Double 30-amp speaker relays(3200.1/4200.1)
- 90% High Density Construction Surface Mount Technology

INSTALLATION

- Please choose a mounting place without any direct weather influences.
- Note that the amplifier generates heat so a well ventilated place is necessary.
- Use at least 8-gauge wire for power and ground connections
- Use at least 12-gauge wire for speaker connections
- Use at least 16-gauge wire for remote connection
- Keep the wire connections as short as possible in order to minimize power loss and provide a higher audio out quality
- Use the shortest ground connection to the chassis of the vehicle and make sure that the paint is removed at the connection point
- Connect the remote input to the remote/antenna output of the head unit
- Mount the fuse holder within 200mm(8") of the vehicle's battery. Use a fuse equal to that specified for your amplifier if a large, single +12V line is run which feeds more than one amplifier add up all required fuse ratings and use the total rating for the fuse
- Connect the speaker to the amplifier observing the correct phasing.
- Make sure that none of the speaker connections can touch the vehicle chassis
- Connect the RCA inputs to the appropriate signal source using only thehighest quality RCA cables
- Make sure that the RCA and speaker cables do not run parallel to the +12V wiring

WIRING INSTRUCTIONS

Power Connection

The battery terminal(+12V) must be connected directly to the positive terminal of the vehicle's battery to provide an adequate voltage source and minimize noise. Connecting the battery terminal lead to any other point(such as the fuse block) will reduce the power output and may cause noise and distortion. Use only 8 AWG or thicker(smaller AWG) wire for this lead and connect it to the terminal of the battery after all other wiring is completed.

Ground Connection

The ground terminal(GND) connection is also critical to the correct operation of the amplifier. Use a wire of the same gauge as the power connection(8 AWG or thicker) and connect it between the ground terminal(GND) of the amplifier and a metal part of the vehicle close to the mounting location. This wire should be as short as possible and any paint or rust at the grounding point should be scraped away to provide a clean metal surface to which the end of the ground wire can be screwed or bolted.

Remote Turn-on Connection

The amplifier is turned on by applying +12V to the remote turn-on terminal(REM). The wire lead to this terminal should be connected to the "Auto-Antenna" lead from the head unit. If the head unit does not provide an "Auto-Antenna" lead, the remote turn-on lead may be wired to an "Accessory" or "Radio" terminal in the vehicle's fuse block. This will turn the amplifier on or off with the ignition key regardless of whether the head unit is on or off. The remote turn-on lead does not carry large currents. So 20 AWG wire may be used for this application.

Speaker Connection

Depending on the type and number of speakers, connect them to the speaker terminals as shown in the appropriate wiring diagram. For most applications, 16 AWG wire would be adequate, but in no case thinner than 18 AWG. For leads more than 10 feet long, 14 AWG is recommended. When wiring the speakers, pay special attention to the polarity of the terminals. Do not ground any speaker leads to the chassis of the vehicle.

Input Connection

Caution! Use either the low-level or high-level inputs on the amplifier. Do not use both at the same time. If the head unit does not provide low-level outputs, the amplifier may be connected via the speaker(high-level) outputs from the head unit. Wire the speaker leads from the head unit to the 5-pin adaptor harness as shown in the diagram(shielded cable is not required) and plug the connector into the input connector on the amplifier. Carefully splice and insulate all wire connection.

CONNECTIONS

[Bridged Wiring]

▲ 4-channel [CTX-1000.4] Amplifiers

RCA Connection

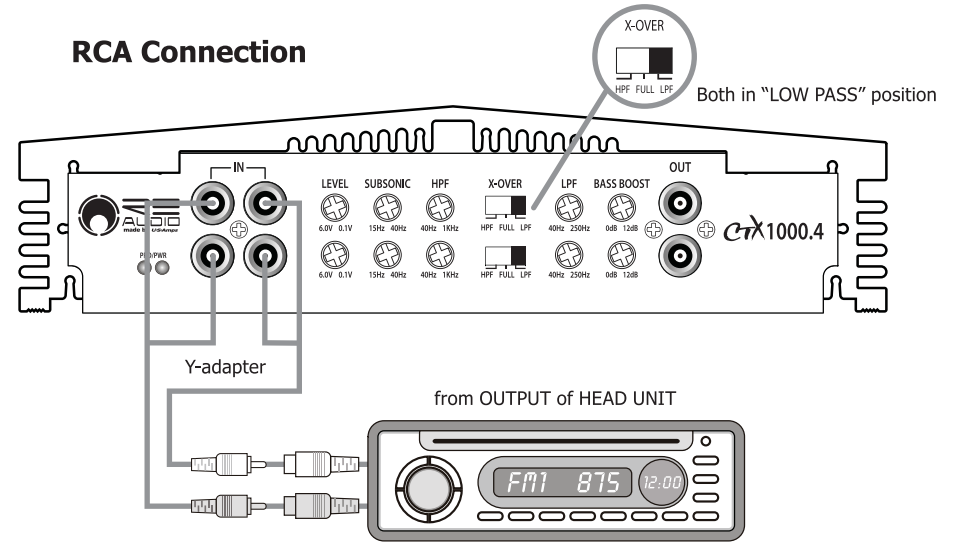

Power & Speaker Connection

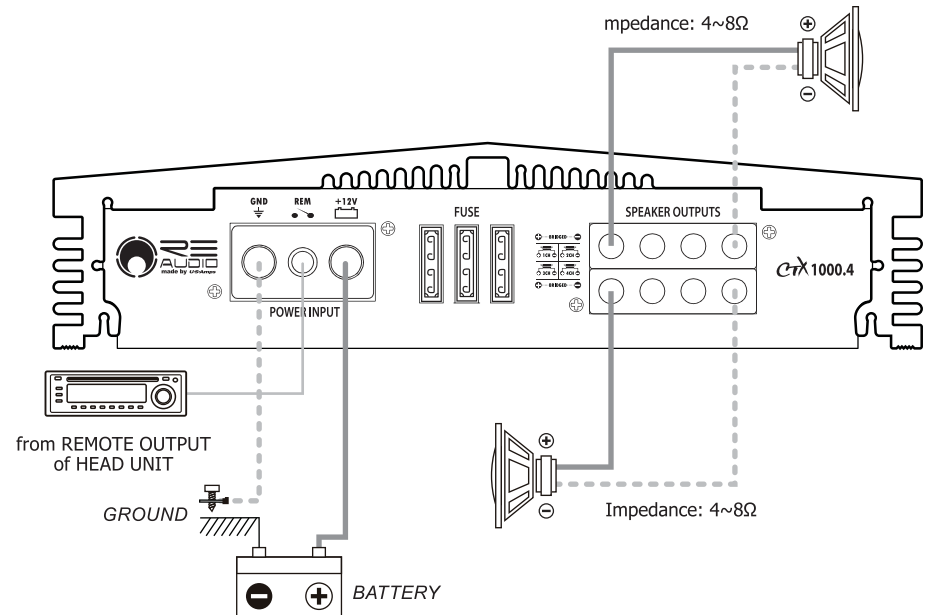

CONNECTIONS

[Bridged Wiring]

▲ 2-channel [CTX-1600.2] Amplifiers

RCA Connection

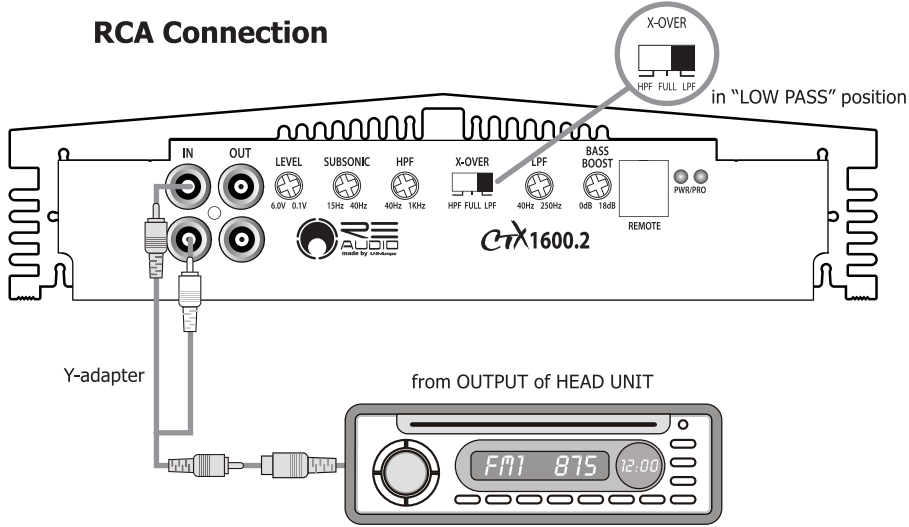

Power & Speaker Connection

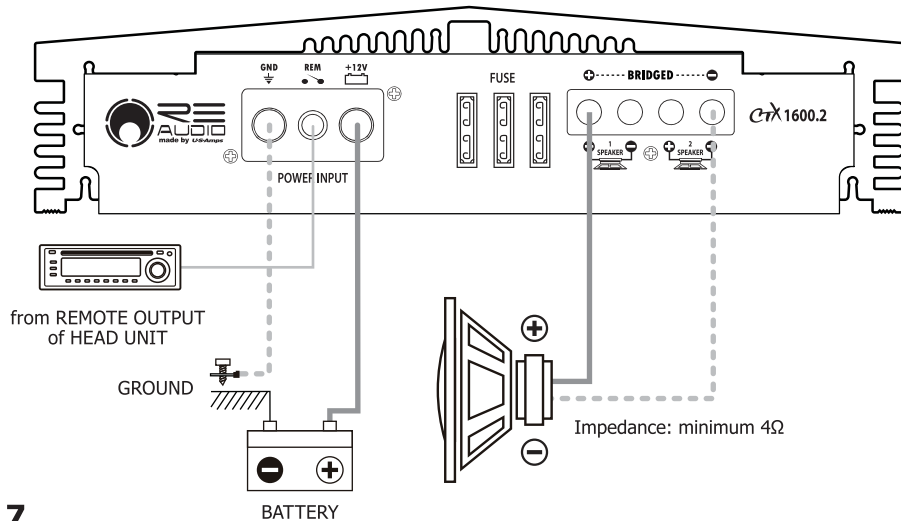

CONNECTIONS

[Basic Wiring]

▲ Monoblock [CTX-4200.1/3200.1] Amplifiers

RCA Connection

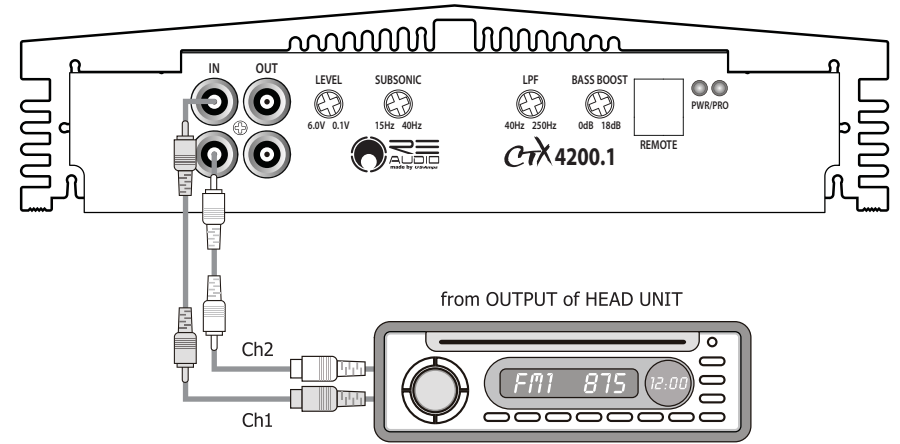

Power & Speaker Connection

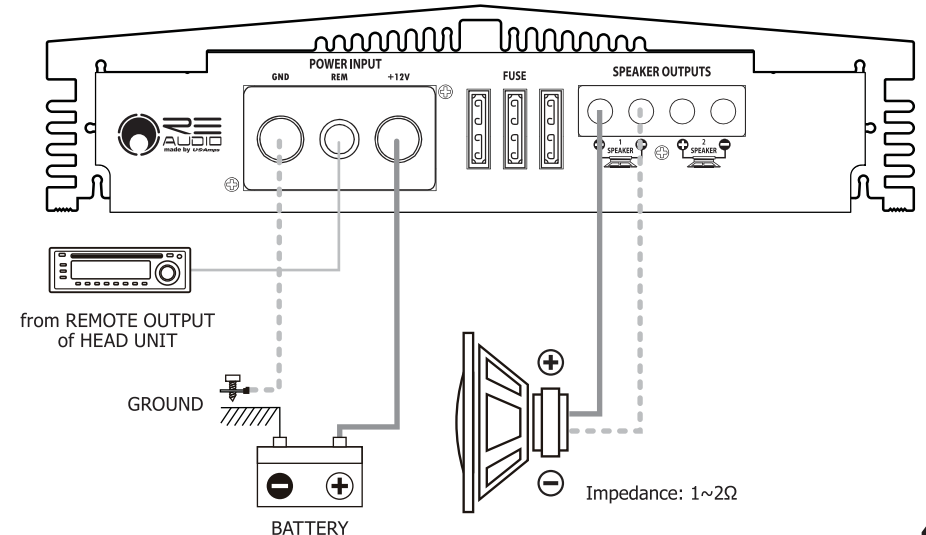

CONNECTIONS

[Basic Wiring]

▲ 2-channel [CTX-1600.2] Amplifiers

RCA Connection

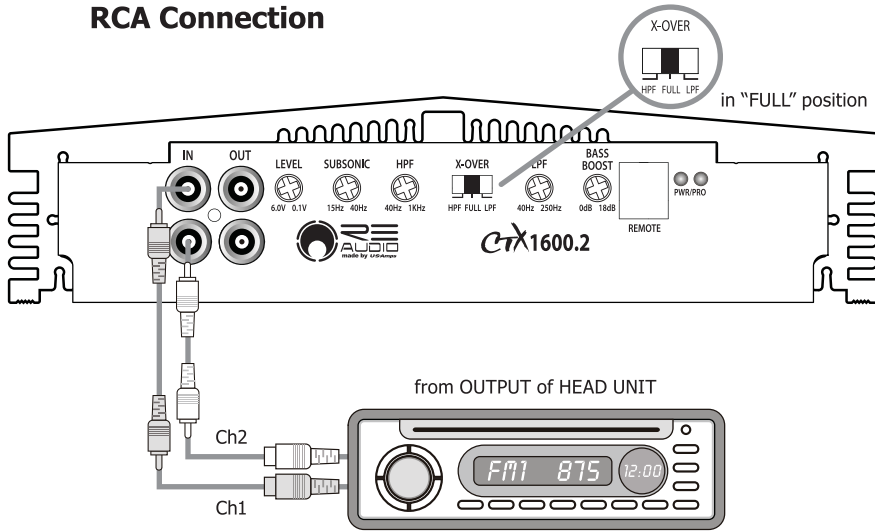

Power & Speaker Connection

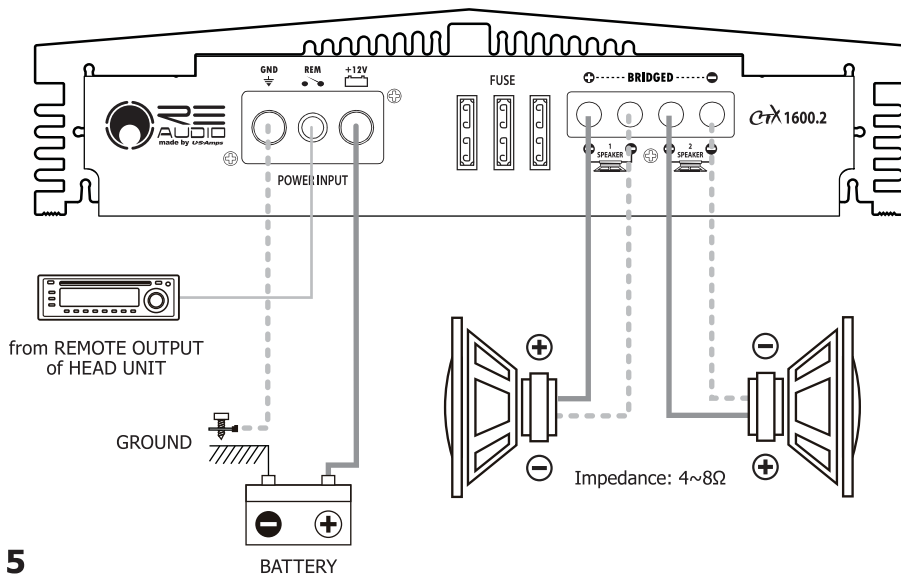

CONNECTIONS

[Basic Wiring]

▲ 4-channel [CTX-1000.4] Amplifiers

RCA Connection

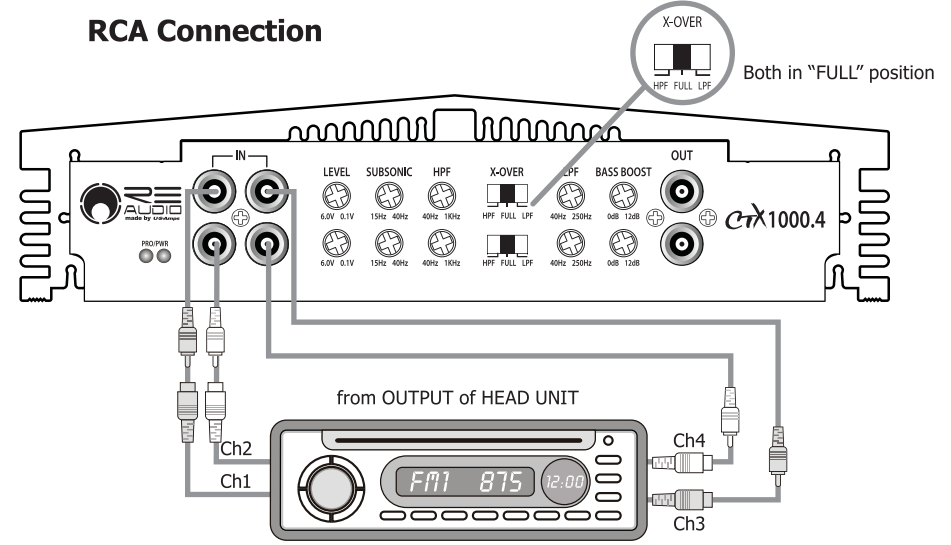

Power & Speaker Connection

